

Example

KALEIDOSCOPE

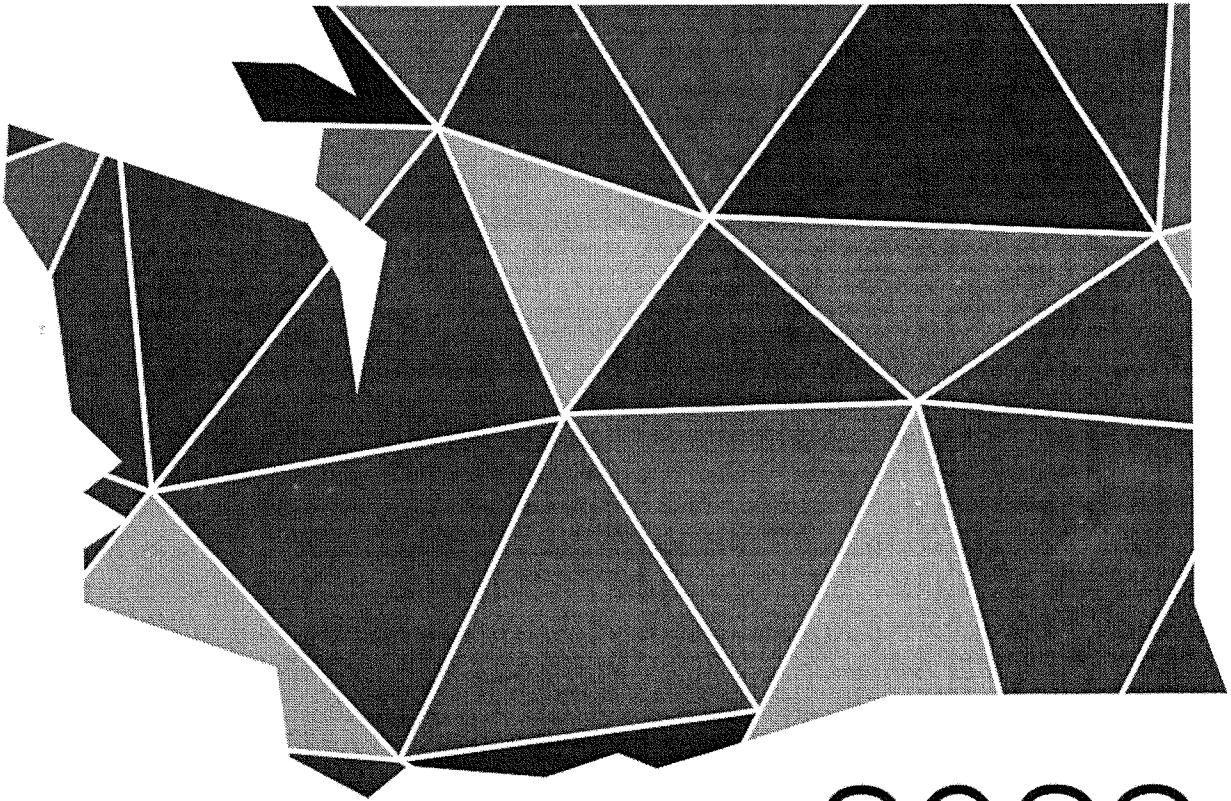

TACOMA LITTLE THEATRE 2023

FESTIVAL INFORMATION PACKET



INDEX

Welcome

Participating Theatres

Contact Information

Hotel Information

Event Schedule

Ticketing and Event Information

ADA Accessibility

Theatre Information

Stage Specifications

Audio/Video Information

Lighting Information

Deadlines and Required Documents

AACTFest 2023 Handbook

Checklist

[LINK TO KALEIDOSCOPE DOCUMENTS](#)

210 N I Street • Tacoma, WA 98403 • 253-272-2281

Email: kaleidoscope@tacomalittletheatre.com • Website: www.tacomalittletheatre.com/kaleidoscope



WELCOME

Hello fellow theatre lovers!

Tacoma Little Theatre is honored to be serving as your host theatre for Kaleidoscope 2023! Included in this packet are all the important deadlines, schedules, schematics, and technical specifics that will help you prepare for the festival process.

Please always make sure that you are utilizing the most up-to-date information. The most current version of this packet will always be available on the Kaleidoscope page of the TLT website.

www.tacomalittletheatre.com/kaleidoscope

You will also be receiving a link to a Google Drive folder that will be available for you to utilize during the festival process. In the next few weeks there will be some marketing materials in the folder for you to utilize as well.

Please feel free to reach out with any questions that you may have. We're here to help make this experience as easy and as much fun as possible.

Best,

Chris Serface
Kaleidoscope 2023 Festival Chair
Managing Artistic Director, Tacoma Little Theatre

PARTICIPATING COMPANIES (as of 12/30/22)

Bellingham Theatre Guild

When Jack Met Jill

Bremerton Community Theatre

Doubt: A Parable

Pullman Civic Theatre

Trying

Stage Left Theater

Pass Over

Stage West Community Theatre

12 Incompetent Jurors

Theatre33

Mind Games



FESTIVAL CONTACT INFORMATION

Host Theatre

Tacoma Little Theatre
210 N I Street
Tacoma, WA 98403
www.tacomalittletheatre.com
flt@tacomalittletheatre.com
Facebook: Tacoma Little Theatre
Twitter: @TLT1918
Instagram: tacomalittletheatre

Festival Chair

Chris Serface
chris@tacomalittletheatre.com
360-556-5735

Festival Technical Director

Blake York
blake@tacomalittletheatre.com
253-202-6194

Festival Production Manager

Dylan Twiner
dylan@tacomalittletheatre.com
253-549-6220

General Festival Questions and Information

kaleidoscope@tacomalittletheatre.com
253-272-2281

Washington State Community Theatre Association President

Ted Miller
ted.miller@wscta.org
509-521-3449

HOST HOTEL



LaQuinta Inn & Suites by Wyndham
1425 E 27th Street
Tacoma, WA, 98421

ROOM RATE: \$99.00 +tax

(One King Bed or Two Double Beds)

Room includes: Free high-speed WiFi, free continental breakfast, mini-fridge, microwave, AC, bathtub/shower, coffee maker, hair dryer, HDTV, bathroom amenities, alarm clock, desk, cribs available, down/feather pillows, iron, pillow-top mattress.

Follow this link (<https://www.wyndhamhotels.com/laquinta/tacoma-washington/la-quinta-tacoma-seattle/rooms-rates?&checkInDate=02/08/2023&checkOutDate=02/12/2023&groupCode=CGW208>) or call 253-383-0146 extension #5 for the front desk no later than January 25th and to reference the group name "WSCTA Kaleidoscope Festival".

TENTATIVE SCHEDULE*

Friday, February 10, 2023		
8:00am	8:30am	Load in #1 & #2
8:30am	10:10am	Tech meeting and rehearsal for #1
10:15am	11:55am	Tech meeting and rehearsal for #2
12:00pm	12:30pm	Load out #1 & #2
12:30pm	1:00pm	Load in #3 & #4
1:00pm	2:40pm	Tech Meeting and rehearsal for #3
2:45pm	4:25pm	Tech Meeting and rehearsal for #4
4:30pm	5:00pm	Load out #3 & #4
5:00pm	6:00pm	Dinner break
6:00pm	6:30pm	Load in #1 & #2
7:00pm	7:10pm	Welcome and Introductions
7:10pm	8:50pm	Show #1 and Adjudications
9:00pm	10:40pm	Show #2 and Adjudications
10:45pm	11:15pm	Load Out #1 & #2
10:45pm		Afterglow Celebration (Location TBD)

Saturday, February 11, 2023		
8:00am	8:30am	Load in #5 & #6
8:30am	10:10am	Tech meeting and rehearsal for #5
10:15am	11:55am	Tech meeting and rehearsal for #6
12:00pm	12:30pm	Load out #5 & #6
12:30pm	1:00pm	Load in #3 & #4
1:30pm	1:40pm	Welcome and Introductions
1:40pm	3:20pm	Show #3 and Adjudications
3:30pm	5:10pm	Show #4 and Adjudications
5:10pm	5:40pm	Load out #3 & #4
5:45pm	6:15pm	Load in #5 & #6
7:00pm	7:10pm	Welcome and Introductions
7:10pm	8:50pm	Show #5 and Adjudications
9:00pm	10:40pm	Show #6 and Adjudications
10:45pm	11:15pm	Load Out #5 & #6
10:45pm		Afterglow Celebration (Location TBD)

Sunday, February 12, 2023		
10:00am		Awards Brunch at LaQuinta (Cedar Room) \$20.00 p/person
10:45am	11:30am	Awards Ceremony
11:30am	12:00pm	Adjudicators meet with advancing companies

*This schedule is tentative based on a six-show schedule. If more theatres enter the festival, the first show will tech and perform on Thursday, February 9th.

EVENT INFORMATION*

TICKETS

Performance Blocks (Two productions in each block) \$15.00

Festival Pass (All entered productions) \$35.00

All seating is General Admission

All individuals who are part of the cast and crew of a festival production receive a free Festival Pass

Tickets will be available for purchase beginning January 16, 2023, online, in-person, or via phone from Tacoma Little Theatre.

AFTERGLOW

Information, schedule and pricing are forthcoming.

AWARDS BRUNCH

Located in the Cedar Room at LaQuinta \$20.00

Sunrise Buffet-Assorted pastries and muffins, scrambled eggs with cheddar cheese, crisp bacon, sausage links, home-style potatoes & sliced seasonal fresh fruit

All individuals who are part of the cast and crew of a festival production receive an awards brunch pass.

All additional awards brunch tickets must be purchased no later than February 2, 2023, online, in-person, or via phone from Tacoma Little Theatre.

*This information is tentative and based on a six-show schedule. If more theatres enter the festival, pricing for festival passes will change.



ADA ACCESSIBILITY

- Public Entrances to the theatre have no steps.
- The stage door has one step down to stage level.
- The backstage alley door requires stepping up a street curb.
- The loading door enters at stage level.
- The stage is wheelchair accessible for actors via the loading door or backstage alley door.
- The lobby has a restroom for men and women, and one ADA accessible single restroom that is for all genders.
- The auditorium has no steps and is ADA accessible with five designated seats that can be removed for wheelchairs and adjacent seats for companion use. Ushers park mobility devices in a safe area at the back of the auditorium once patrons have been sat.
- Assisted listening devices are available for patrons to borrow.

THEATRE INFORMATION

Tacoma Little Theatre is a national award-winning community theatre that has been offering quality productions and educational programs to the Pacific Northwest since 1918. TLT has been in its current home since 1940. During 2020-2021, TLT remodeled its auditorium and lobby, creating a newly revitalized space seating 215 patrons.

- Public Entrances to the theatre have no steps.
- The stage door has one step down to stage level.
- The backstage alley door enters at stage level.
- The loading door enters at stage level.
- The stage is wheelchair accessible for actors via the loading door or backstage alley door.
- The lobby has a restroom for men and women, and one ADA accessible single restroom that is for all genders.
- The auditorium is ADA accessible with five designated seats that can be removed for wheelchairs and adjacent seats for companion use. Ushers park mobility devices in a safe area at the back of the auditorium once patrons have been sat.
- Assisted listening devices are available for patrons to borrow.

Please note the following specifics for companies participating in the festival:

- Tacoma Little Theatre does not have fly space.
- Two 10' x 10' staging squares will be located behind the traveler.
- Companies will not be allowed to screw into the stage floor or walls.
- There is no on-site storage for sets. Companies will load-in at the beginning of their tech block and load-out after both companies have completed their rehearsals.
- Load-in and load-out will take place through the loading door located stage left. Following your load-out you will need to move your transport vehicle to the designated waiting area.



STAGE SPECIFICATIONS

Following this page, you will find the following information:

TLT Full Building Schematic
TLT Stage Headers
TLT Stage Dimensions
TLT Kaleidoscope Stage Diagram
TLT Stage Side Elevation Dimensions
TLT Stage Side Elevation Blank

For questions regarding the stage, please contact

Blake York

Technical Director

blake@tacomalittletheatre.com

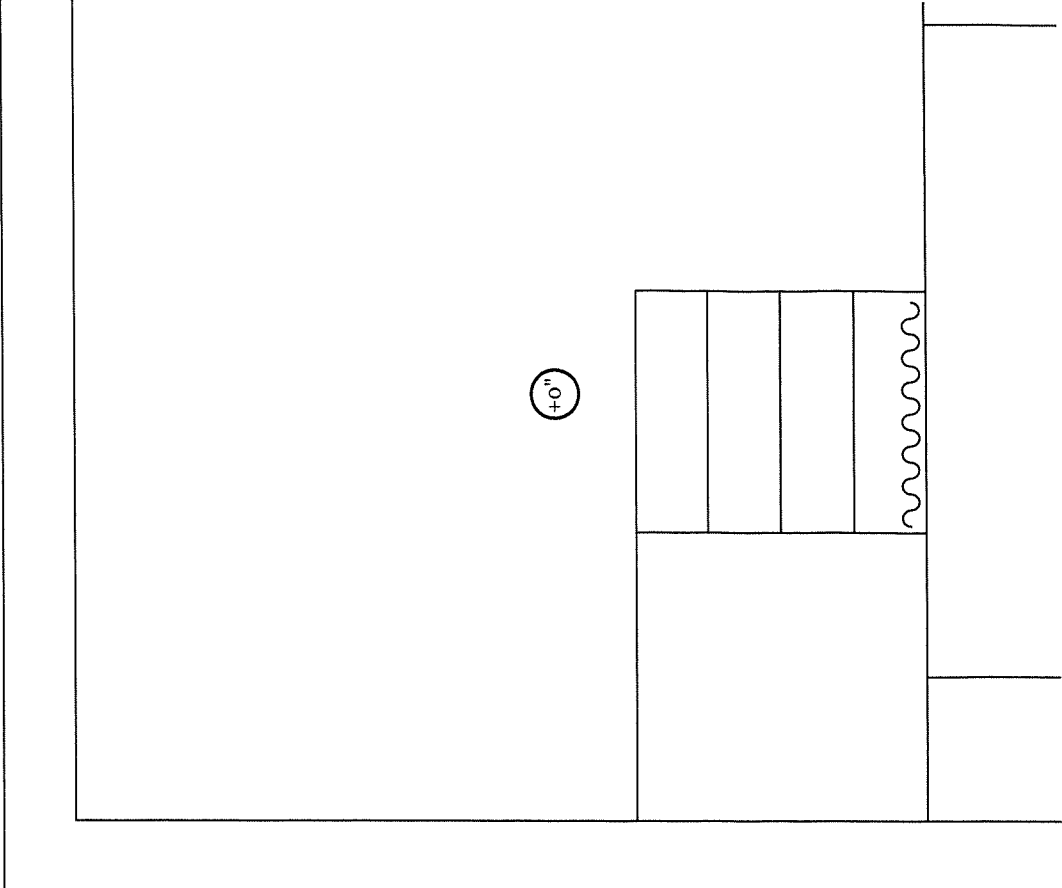

AUDIO/VIDEO INFORMATION

Sound Board

Behringer Wing digital mixing console

Basics: 48 input channels, 24 bus, 24 faders

Specifications: www.behringer.com/product.html?modelCode=POBV2

Cables

XLR, 1/4" readily available

Sound Capability

CD/USB/Laptop

Programming

QLab 5.0.12

running on a Mac Studio, macOS Ventura Apple M1 Ultra chip

For acceptable formats [CLICK HERE](#)-video [CLICK HERE](#)-audio

Speakers

2 Presonus ULT12 (Rear)

4 Presonus ULT15 (Front and Mid)

1 Mackie SRM450 monitor suspended over the stage

Microphones

2 AKG PCC160 floor microphones if desired

Intercom System

6 UltraLITE HD Ear Tech radio headsets

HDMI

HDMI runs from the tech booth to mid-stage right floor port

For questions regarding audio/video, please contact

Dylan Twiner

Production Manager

dylan@tacomalittletheatre.com



LIGHTING INFORMATION

Tacoma Little Theatre's lighting system utilizes an ION XE Lighting Console with 2048 Outputs and 20 faders

Technical Specifications

<https://www.etconnect.com/Products/Consoles/Eos-Consoles/Ion-Xe/Features.aspx?LangType=1033>

Following this page, you will find the following information:

TLT Light Plot-Trim
TLT Light Plot-Focus
TLT Light Plot-Hang
TLT Instrument Schedule (2 pages)
TLT Lighting Inventory

For questions regarding lighting, please contact
Niclas Olson
TLT Resident Lighting Designer
lights@tacomalittletheatre.com

3 Electric

13'-0"

Truss

2 Electric

12'-0"

1 Electric

12'-0"

Proscenium

1 AP

11'-0"

2 AP

11'-0"

3 AP

12'-0"

Center Line

SR Boom 1

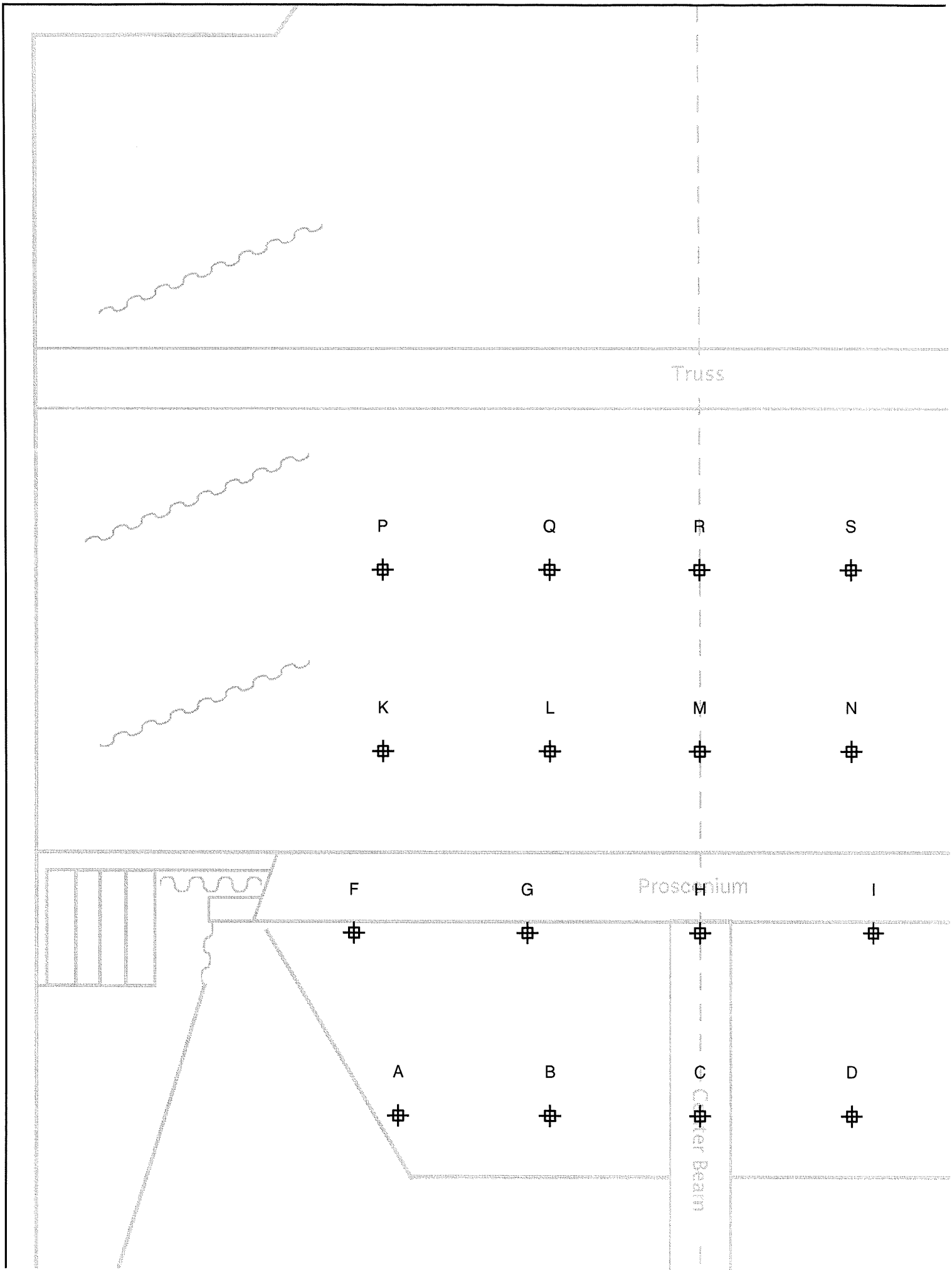

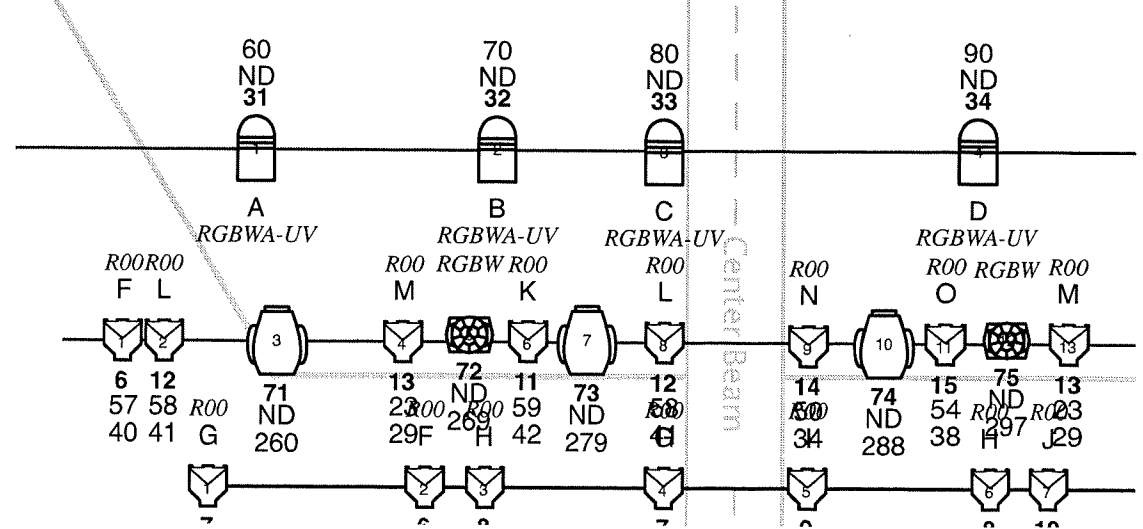
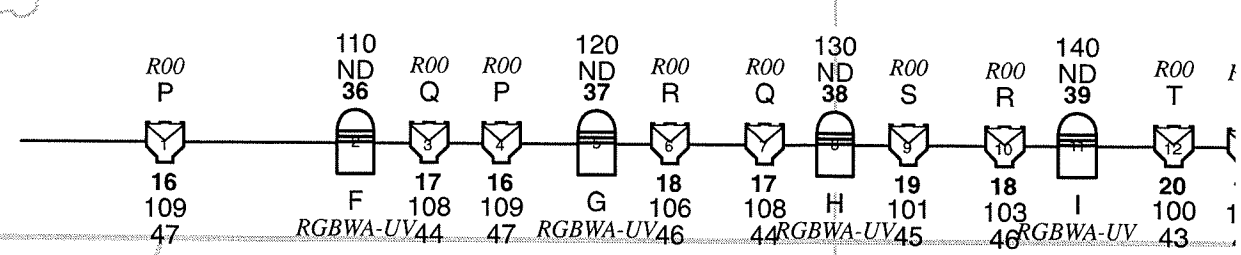
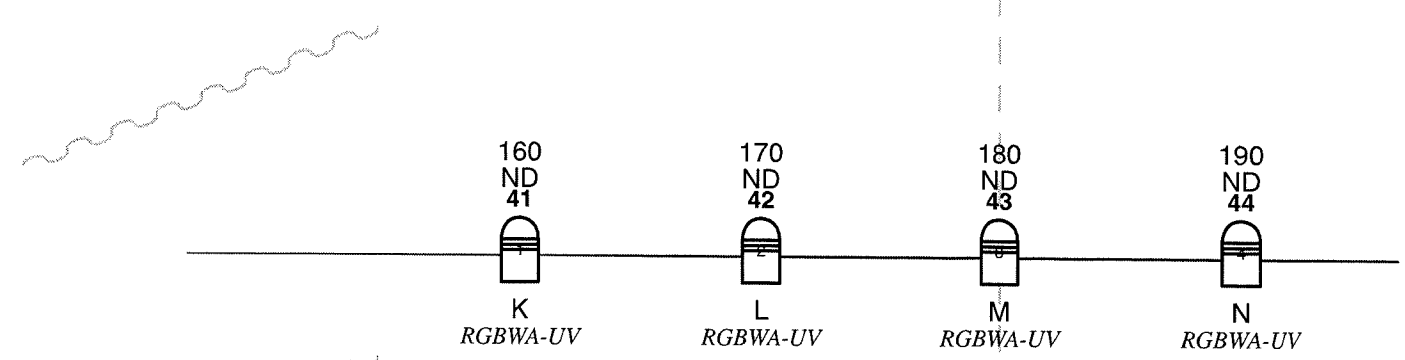
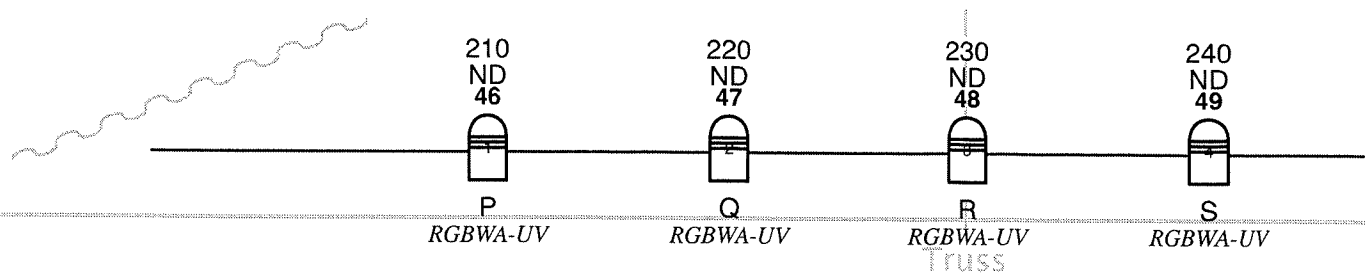

Rep Plot

#	Position	Use	Chan	Dim	Circ	Type	Color
1	4 AP	A	1	33	29	Sc4 Par WFL 575w	R00
2	4 AP	B	2	32	28	Sc4 Par WFL 575w	R00
3	4 AP	A	1	33	29	Sc4 Par WFL 575w	R00
4	4 AP	C	3	30	26	Sc4 Par WFL 575w	R00
5	4 AP	B	2	32	28	Sc4 Par WFL 575w	R00
6	4 AP	D	4	27	21	Sc4 Par WFL 575w	R00
7	4 AP	C	3	30	26	Sc4 Par WFL 575w	R00
8	4 AP	E	5	26	20	Sc4 Par WFL 575w	R00
9	4 AP	D	4	27	21	Sc4 Par WFL 575w	R00
10	4 AP	E	5	26	20	Sc4 Par WFL 575w	R00
1	3 AP	G	7	39	55	Sc4 Par WFL 575w	R00
2	3 AP	F	6	40	57	Sc4 Par WFL 575w	R00
3	3 AP	H	8	37	53	Sc4 Par WFL 575w	R00
4	3 AP	G	7	39	55	Sc4 Par WFL 575w	R00
5	3 AP	I	9	35	51	Sc4 Par WFL 575w	R00
6	3 AP	H	8	37	53	Sc4 Par WFL 575w	R00
7	3 AP	J	10	36	52	Sc4 Par WFL 575w	R00
8	3 AP	I	9	35	51	Sc4 Par WFL 575w	R00
1	2 AP	F	6	40	57	Sc4 Par WFL 575w	R00
2	2 AP	L	12	41	58	Sc4 Par WFL 575w	R00
3	2 AP		71	260	ND	Moving Spot	Color Wheel
4	2 AP	M	13	29	23	Sc4 Par WFL 575w	R00
5	2 AP		72	269	ND	Moving Wash w/ Zoom	RGBW
6	2 AP	K	11	42	59	Sc4 Par WFL 575w	R00
7	2 AP		73	279	ND	Moving Spot	Color Wheel
8	2 AP	L	12	41	58	Sc4 Par WFL 575w	R00
9	2 AP	N	14	34	50	Sc4 Par WFL 575w	R00
10	2 AP		74	288	ND	Moving Spot	Color Wheel
11	2 AP	O	15	38	54	Sc4 Par WFL 575w	R00
12	2 AP		75	297	ND	Moving Wash w/ Zoom	RGBW
13	2 AP	M	13	29	23	Sc4 Par WFL 575w	R00
14	2 AP		76	307	ND	Moving Spot	Color Wheel
15	2 AP	N	14	34	50	Sc4 Par WFL 575w	R00
16	2 AP	J	10	36	52	Sc4 Par WFL 575w	R00
1	1 AP	A	31	60	ND	LED Par64 RGBWA-UV	RGBWA-UV
2	1 AP	B	32	70	ND	LED Par64 RGBWA-UV	RGBWA-UV
3	1 AP	C	33	80	ND	LED Par64 RGBWA-UV	RGBWA-UV
4	1 AP	D	34	90	ND	LED Par64 RGBWA-UV	RGBWA-UV
5	1 AP	E	35	100	ND	LED Par64 RGBWA-UV	RGBWA-UV

Rep Plot

1	1 Electric	P	16	47	109	Sc4 Par WFL 575w	R00
2	1 Electric	F	36	110	ND	LED Par64 RGBWA-UV	RGBWA-UV
3	1 Electric	Q	17	44	108	Sc4 Par WFL 575w	R00
4	1 Electric	P	16	47	109	Sc4 Par WFL 575w	R00
5	1 Electric	G	37	120	ND	LED Par64 RGBWA-UV	RGBWA-UV
6	1 Electric	R	18	46	106	Sc4 Par WFL 575w	R00
7	1 Electric	Q	17	44	108	Sc4 Par WFL 575w	R00
8	1 Electric	H	38	130	ND	LED Par64 RGBWA-UV	RGBWA-UV
9	1 Electric	S	19	45	101	Sc4 Par WFL 575w	R00
10	1 Electric	R	18	46	103	Sc4 Par WFL 575w	R00
11	1 Electric	I	39	140	ND	LED Par64 RGBWA-UV	RGBWA-UV
12	1 Electric	T	20	43	100	Sc4 Par WFL 575w	R00
13	1 Electric	S	19	45	101	Sc4 Par WFL 575w	R00
14	1 Electric	J	40	150	ND	LED Par64 RGBWA-UV	RGBWA-UV
15	1 Electric	T	20	43	100	Sc4 Par WFL 575w	R00
1	2 Electric	K	41	160	ND	LED Par64 RGBWA-UV	RGBWA-UV
2	2 Electric	L	42	170	ND	LED Par64 RGBWA-UV	RGBWA-UV
3	2 Electric	M	43	180	ND	LED Par64 RGBWA-UV	RGBWA-UV
4	2 Electric	N	44	190	ND	LED Par64 RGBWA-UV	RGBWA-UV
5	2 Electric	O	45	200	ND	LED Par64 RGBWA-UV	RGBWA-UV
1	3 Electric	P	46	210	ND	LED Par64 RGBWA-UV	RGBWA-UV
2	3 Electric	Q	47	220	ND	LED Par64 RGBWA-UV	RGBWA-UV
3	3 Electric	R	48	230	ND	LED Par64 RGBWA-UV	RGBWA-UV
4	3 Electric	S	49	240	ND	LED Par64 RGBWA-UV	RGBWA-UV
5	3 Electric	T	50	250	ND	LED Par64 RGBWA-UV	RGBWA-UV
1	SR Boom 1	K	11	42	59	Sc4 Par WFL 575w	R00
1	SR Boom 2	ASL	103	27	Direct	Sc4 Par WFL 575w	R00
1	SL Boom 1	O	15	38	54	Sc4 Par WFL 575w	R00

TLT Lighting Inventory (update 12/28/2022)

PRIMARY STOCK

45 ETC Source 4 Par @ 575w (40 in rep plot)
(Standard WFL, other lenses in stock)
2 ETC Source 4 Parnel @ 575w (1 in rep plot)
9 ETC Source 4 Ellipsoidal @ 575w
6 x 50* Barrel
4 x 36* Barrel
7 x 26* Barrel
3 x 19* Barrel
20 Stageright RGBWA-UV LED Par (20 in rep plot)
6 ETC 11" Selador LED (80* vert. and hor. lenses in stock)
4 Monoprice Moving Spot (13*) with 30w LED
2 Monoprice Moving RGBW Zoom (8-60*) with 7x12w LED

ADDITIONAL INVENTORY (May or may not be functional)

~5 Par56 @ 500w
~3 Par 16
~6 Altman 6x9 @ 750w
~15 RGB LED Par 38 Footlights
1 Scoop @ 1000w
1 Followspot @ 1000w

ACCESSORIES

~10+ Barndoor (2 in rep plot)
2 Top Hat (1 in rep plot)
1 Sc4 Iris
10 Sc4 Pattern Holder

GRAVEYARD

1 ETC Source 4 Ellipsoidal @ 575w (repair burner assembly)



DEADLINES

AACT Required

all are due January 16, 2023

T1-AACTFest 2023 Entry Information (online)

<http://aact.org/aactfest-company-entry-information-form-t1>

T2-AACTFest 2023 Warranty of Company Compliance (online)

<http://aact.org/aactfest-warranty-company-compliance-t2>

T3-AACTFest 2023 Affidavits of Actor Eligibility (physical form)

[http://aact.org/sites/default/files/affidavit of actor eligibility form 2023.pdf](http://aact.org/sites/default/files/affidavit%20of%20actor%20eligibility%20form%202023.pdf)

T4-AACTFestival 2023 Technical Information (online)

<http://aact.org/aactfest-technical-information-t4>

KALEIDOSCOPE Required

Script Submittal due ASAP

Per AACT, you must submit four scripts marked as intended to be performed. (The adjudicators are required to read the scripts in advance.) Do not photocopy any scripts without proper permission from the playwright or publisher. Additional scripts may be required for interpreters or other personnel, but only with sufficient notice to the company. Kaleidoscope 2023 must receive your scripts by January 16, 2023. Mail them to: Tacoma Little Theatre, 210 N I Street, Tacoma, WA 98403. Scripts will be returned to you after the festival, with the exception of the two companies that advance to the regional festival.

Program Information due January 29, 2023

Follow this link to submit program information

<https://forms.gle/KnwFQhkpe99FMYBTA>

210 N I Street • Tacoma, WA 98403 • 253-272-2281

Email: kaleidoscope@tacomalittletheatre.com • Website: www.tacomalittletheatre.com/kaleidoscope